

# FUEL-LESS ENGINE

## TABLE OF CONTENTS

<b>Generator.....</b>	<b>2</b>
<b>The Making of a Gray Generator.....</b>	<b>2</b>
<b>Working Principle of a Generator (for beginners).....</b>	<b>9</b>
<b>Plan.....</b>	<b>10</b>
<b>Parts List.....</b>	<b>21</b>
<b>Timing of a Fuel-less Engine.....</b>	<b>24</b>
<b>How to Build a Commutator.....</b>	<b>28</b>
<b>Ceramic Magnets (Introduction).....</b>	<b>32</b>



# GRAY GENERATOR

If you are considering building your own motor/ engine using our guide, we advise you build it for your own use only and keep it from family, friends and the news media. The Generator Engine we built is a spin of the Ed Gray motor as well as a combination of both our designs and the Newman design. Furthermore, this generator is highly flexible since you can run it on 300 to 1000 volts dc, (using a special coil design as well as the designs included in these plans).

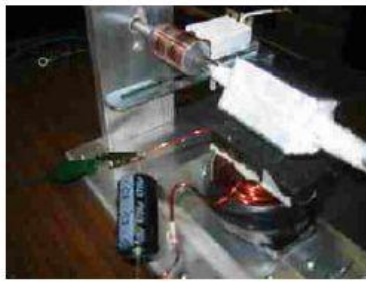
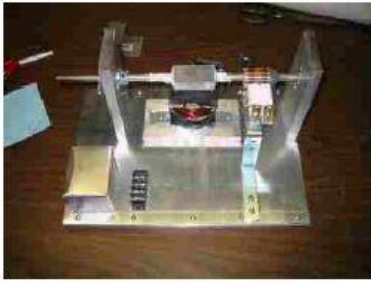

## THE MAKING OF A GRAY GENERATOR

Making a gray generator is not a difficult task, you can approach it by making the outer shell case out of just about anything you want to but it's recommended to use steel tubing or aluminum tubing for anything over 100 hp. Anything below that you can use 1/2" plywood box. PVC sewer pipe can also be used.

## Pole design

All magnets in the north and south positions push themselves apart with great force in order to because the rotor shaft to turn that ultimately runs the motor forward or reverse. This is our first prototype model and it is highly flexible since it can be scaled up and down to any desired power of your choice and you can even improve on this original design. The most interesting part is that anyone can follow this guide and build this motor. There are no requirements for building a motor based on the instructions given in this guide. You don't have to be an Engineer and you even don't need any prior experience in the art of Electric Motor building or repair. All you need is just the ability to read. All you have to do now is to check at your local library and you have all the resources needed to get a basic understanding of DC Motor designs.

At the basic level, all HV electromagnets are wired NorthPole to North Pole. But if you wish to make an attraction motor all you have to do is wire and time the Poles to attract each other.

2-4 spark plugs will be used as high voltages switches in order to send a DC voltage to 4 coils at a time. The engine can be designed in any way but the main working principle remains the same. It will be much easier to turn



on a slow rpm drill press if the magnets are about 4 to 6" long.

Wrapping the coil with #31 wire at about 150 RPMs works best, 250 RPMs is a little faster but can be done. It's recommended to build a one Hp or less fuel-less DC motor first.

Different types of magnet coils have been made to run a small test motor and the size wire which was amperage hog and the one which proved worthy to be used in free energy motor was discovered. It was found that #36 fine hair wire was the best but harder to work with and the #30 copper coated wire will work but the #36 is better with high voltage, thousands of winds and a PVC plastic air core bobbin type coil.



During our early days of testing, we had to make different types of magnet coils to run our small test motor, we ensured that we did everything and left no stone unturned. But something great happened, we discovered which size wire was an amperage hog and which one was

worthy enough to be used in our free energy motor. We found that the #36 fine hair wire was the best but we also discovered that it was harder to work with. #30 copper coated wire will work, but #36 is better using thousands of winds, High Voltage and a PVC plastic Air core bobbin type coil

In this guide, we are going to show you the simple secret of the Ed gray Engine, step by step, and the Fuel-less Engine, and also show you how to build your own step by step. The Ed Gray US Patent reveals much but not all, they left out the most important part such as size of wire to use for the high voltage electromagnets and how many turns of wire that will be required.

You don't have to be an engineer or scientist to follow this guide, all you have to do is read the guide carefully and follow all the instructions and precautions step by step. We know of one customer, who was not even an engineer and never went to College and he built our Gray Engine with no problem because he knew what I am about to tell you is common sense, followed all the instructions step by step and he put his engine inside of an old caddy!

With this information you will be able to build a powerful free energy electrical motor to run a 20 kW 120 vac generator to run your home and even your business. Knowledge is power and the information is right here in this book, in your hands.

We believe that the next 1000 years will be self-powering, that is, one hundred percent sustainable and many homes will be enjoying free energy in the comfort of their homes. Our purpose is to reveal the simple secret of the Ed Gray engine and the Fuel-less Engine. Although the Ed Gray U.S. Patent has already revealed much but the information is not sufficient to build a Fuel-less Engine all by yourself. Hence the need to read our guide and follow step-by-step.

But we have a little request to make. All we ask is that you keep all of this to yourself, this is TOP SECRET STUFF! Just build them for yourself and keep it to yourself.

By buying these plans and opening this envelope, you agree to keep this information contained in these plans to yourself, you agree not to try and manufacture this engine or show a working model to the news media, unless you get permission from us. We have redesigned this engine and therefore have rights to this information, anyone trying to copy these plans or manufacturing the Gray engine without our permission will face legal action. Gray- is Copy written 2002. (You can build them for your own use.)

This Engine Motor Generator is just a basic industrial HV DC electric motor that can be scaled up or down to any power rating that you desire. But the special part about this motor engine is it is free energy! Keep all electromagnets firing North to North. We recommend you use

permanent magnets on the rotor instead of electromagnets in order to make it easier to build and eliminate the need for brushes. If using permanent rotor magnets you will need to make the motor attract.

We now have a little favor to ask of you, please don't forget to send us a video of your progress, this sometimes will help others if they are having any questions, by sending us your video you are also agreeing that we may use some of the video as promotion for other customers and research engineers to see. Please note that all videos will not be returned. If you are able to come up with any better designs through this guide, whether big or small, it is not uncommon to get a reward. Thank you for purchasing these plans, it helps us grow as a business and a research company, we plan on having many new updates as well as new discoveries that we can share to the world

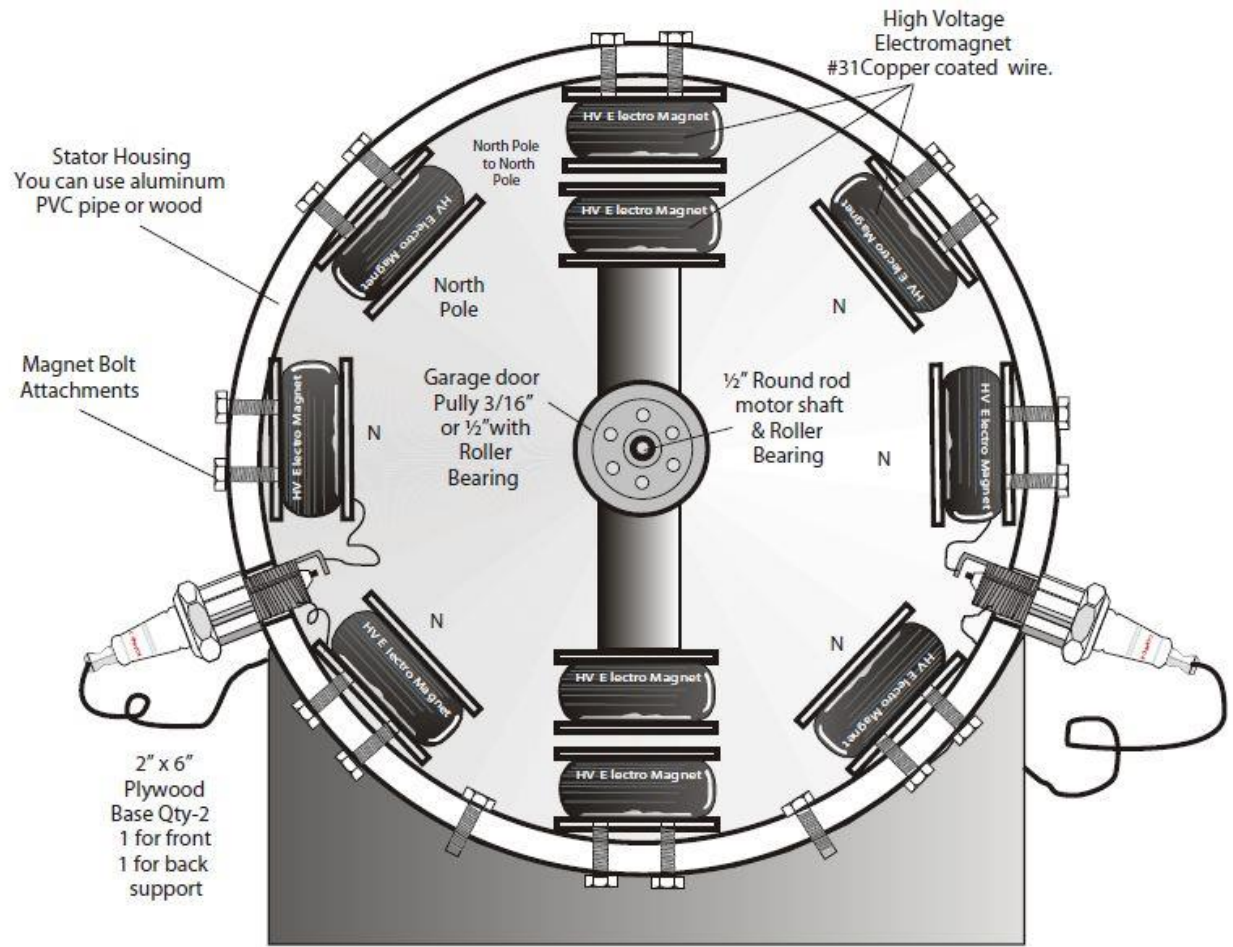

## PARTS LIST

Quantity - One 1000 volt DC power supplies, 60 Hz or best 30 kHz or more. The voltage can be stepped up by using a 115 vac power inverter 60 Hz modified sine wave. Use 1 high voltage step up transformer or use the capacitor and diode step up method. Add enough capacitors and diodes until the voltage is 1,000 vdc.

Quantity-2 Spark Plugs, Champion Copper Plus #855 DJ7Y



Quantity- 2 12 vdc car batteries, car batteries help collect free energy back emf, store it and also run the 1,000 vdc power supplies. The special HV magnets will be used and will only consume very little amperage in the milliamps. Batteries will last a very long time without the back emf.

Quantity- 6 or 10 high voltage electromagnets, a quantity of 10 is optional, the more the magnets the more power. I would suggest starting off with 6 magnets and adding later, turns magnets with #27 copper coated wire since you would be turning thousands of turns, get each turn of wire as close to the other as you can. It does not have to be perfect. But the better you make them the higher the efficiency. Each magnet core must be prepared correctly, make sure you spray each Iron core with 3 to 4 coats of clear lacquer or red spray paint and allowed to dry properly.

Quantity-2 Soft Iron ductal bar from industrial tube and steel.

Quantity-2 1000 vdc capacitor and diode multiplier banks, or a HV automotive power supply. You can also use all the HV voltage supplies like Ed Gray did on his engine but it is not necessary.



## **PLEASE READ**

Thank you for purchasing these plans! You will be glad you did. You need not worry if you don't understand the content and the instructions in these plans at first. That is expected if you are new to the subjects in these plans. These plans have been designed to meet the needs of the complete beginner. You don't have to be bothered if you are completely new to the field of electronics or if you have never worked with electricity before. If you are a complete beginner, all you have to do is go to your local library, or a Radio Shack and get a beginners' book on electronics, electricity, electromagnets and electric motors. These books can also be purchased from online stores like e-Bay. We have sold thousands of these plans and we have many happy clients that built their own fuel-less engine without having any prior experience with electronics. You can also contact us if you need technical help (by E-mail only) and we will try our best to get back to you and answer your questions as fast as we can.

**NOTE:** You can convert an automobile engine into a fuel-less engine for free engine. But in order to avoid having the same troubles that gas engines usually have (such as tears and wears on all mechanical moving parts, oil rings, gaskets etc.) To do it you will need to remove the lifters and head assembly, and redesign the head. You will need two high voltage per piston. Attach one directly to a piston via a metal angled extension and one magnet positioned on top of that one, north and north poles of magnets facing each other. Then you must hook up the capacitor banks and use the distributor timing for each piston to ignite each piston. This causes the magnets to repulse each other taking place of the explosion which takes place in an internal combustion engine. Just like any car engine you will eventually need to have it rebuilt or repaired.

An oil system or a cooling system is not needed to operate the Fuel-less Engine and the Fuel-less Engine never dies. The only parts you will need to replace are the spark plugs *or commutators if you decide to use a commutator system*, spark plug wires and the 2 ball bearings that the shaft rides on. We estimate replacement time every 25 to 30 years. If you build your magnets right they will never break down.

This is not a common or ordinary electric engine / motor, and though it operates with the basic principles of electric motor but it is unique and there is nothing else like it in the entire world. The output is free energy which is used to help rerun the motor by recharging the batteries. Every

HV Electromagnet creates its own energy after power is taken off of it. This electrical phenomenon is called Back E.M.F. and another type of energy I cannot tell you about, But for your knowledge is not needed.

This free energy is converted back to the batteries to recharge them.

**WARNING!** Keep children and adults who do not understand high voltage rules when working with high voltages. Always insulate your hands with protective rubber gloves when working with protective rubber gloves. High voltage is capable of causing death. Please know that we are not responsible for anything in these plans. You build at your own risk.

## **WORKING PRINCIPLE OF A GENERATOR (FOR BEGINNERS)**

An electric motor is essentially just a tight coil of copper wire wrapped around an iron core that's **free to** rotate at high speed inside a powerful, permanent magnet. When you feed electricity into the copper coil, it becomes a temporary, electrically powered magnet—in other words, an electromagnet—and generates a magnetic field all around it. This temporary magnetic field pushes against the magnetic field that the permanent magnet creates and forces the coil to rotate. By a bit of clever design, the coil can be made to rotate continuously in the same direction,

spinning round and round and powering anything from an electric toothbrush to an electric train. So how is a generator different? Suppose you have an electric toothbrush with a rechargeable battery inside. Instead of letting the battery power the motor that pushes the brush, what if you did the opposite? What if you turned the brush back and forth repeatedly? What you'd be doing would be manually turning the electric motor's axle around. That would make the copper coil inside the motor turn around repeatedly inside its permanent magnet. If you move an electric wire inside a magnetic field, you make electricity flow through the wire—in effect, you generate electricity. So keep turning the toothbrush long enough and, in theory, you would generate enough electricity to recharge its battery. That, in effect, is how a generator works. Essentially, the grey generator works by means of a center rotor which rotates within a static housing when it is turned on which results in the capacitor powering up to its firing spark potential. Following this, all you have to do is to spin the shaft by hand or by starter motor. It is recommended that the best motor to build is the 1 horsepower type, which has already been included in these plans and if you need more horsepower all you have to do is to scale it up. Air core electromagnets are the best type of electromagnet to use. It should be remembered that the finer the wire you use and the more turns of wire, the more free energy output that will be generated, however, motor input voltage must be increased. Using a fine and thin wire has its advantages, it will cause

the motor to run with very little amperage at all, and then the free energy back EMF can then be used to replenish the battery's voltage. However, the finer the wire, the harder it is to turn and hair thin wire breaks very easily

## **HOW IT WORKS**

The engine is highly efficient. It gives a great output with a lesser input by using a high voltage AC at 60KHZ in milliamps. The voltage is then converted to DC through the use of diodes which are rated at twice the voltage of the input voltage and then the HV DC is directed to a HV capacitor bank. The most important part of the engine is the capacitor because without the capacitor the engine would not exist in the first place. High voltage in the milliamps can do nothing to a HV electromagnet without the capacitors. The capacitors quickly store the electrons and so produce a great output of free amperage. There is something else that was discovered that happens that is not explainable, something extra is produced by the high voltage that causes this engine to work. When the electrolytic capacitor bank becomes fully charged and the spark plug gap is set to fire at 1000 volts it ignites and a complete circuit is made to the magnets which are facing one another North Pole to North Pole, an explosive amount of magnetic power then

takes place and both magnets repel one another. The power can be used to power a generator to keep up the batteries and to supply power to an entire home. It is impossible to get this much power from a low milliamp source using any other electrical DC motor.

**NOTE: The more voltage you use the more power your engine will have, as well as RPMs.**

## **Plans**

A Gray engine can be built using a 1000vdc  $\times$  10-30 milliamp, the capacitors (microfarad) can now be smaller, now you can use electrolytic capacitors rated 60-200 microfarad and it is much cheaper to build, this brings down the cost of buying large capacitors. An automotive condenser/capacitor can be used. But capacitors that are rated at 1000 volts  $\times$  100 microfarads and solder them together in series. Your motor will be using more voltage and amperage if you use copper coated wire and winding this wire around a soft iron core. This is a crucial part when building the Gray Engine. It is possible to increase power from about 100 to 350 hp if you add more or larger electromagnets. Thus, the larger gauge wire you use the more amperage you will use and the less voltage you will need, this is the way most electrical motors are used today, these motors waste energy and they are not designed to use the back emf of each coil of wire.

Now back to the Fuel-less Engine. For instance, when a #2 wire is used, it is like using a small thin water hose, what volume of water do you think will pass through it? Assuming you now use a large 1/4" water hose more water passes through it. It is the same thing with electrons / current, the larger gauge wire you use the more amperage you will use and the less voltage you will need, this is the way most electrical motors are used today. I like to call these motors amperage hogs! They waste energy! And they are not designed to use the back emf of each coil of wire. The fuel-less engine on the other hand uses #27 wire which uses less amperage and thus generates higher voltages, which by using higher voltages you get more free energy.

You will need two soft iron cores, the first iron core use # 18 copper coated wire with 200 turns, the second iron core use #27 copper coated wire with 2,000 turns, now you will need a 1000 vdc x 47micro farads capacitor or capacitor bank. Place a volt meter on the capacitor and charge the capacitor to 1000 volts. Connect the negative wire of the capacitor to the coil of the first and second iron core electromagnets that you have made. Now connect the Positive wire coming from the 1000 v cap and connect it to each magnet one at a time. If you have done this, you will observe the first magnet will take only 1 to 2 hits before the voltage of the capacitor hits -0-, the second magnet will take about 7 to 10 hits to reach -0-voltage mark. You will notice that the second magnet



that is using the #27 wire consumes less energy to run than does the first magnet (the amperage HOG!).

Wall transformer cores can also be used, you can simply use them squared of which gives you less efficiency or you can cut them to the shape that you like, they are small and the speeds can be adjusted, they use very small drill cutting bits etc. You can sandwich the iron core transformer core in between 1" wood or 1.2" plywood and use a hack saw to cut them. Lamination pieces will come apart if you do not use the wood iron. Also note that the closer the magnets are the more horsepower that will be generated. This also has the added benefit of increasing the lifespan of your magnets. Your model can be a 1/2 horse power motor using small 2 amp wall transformers then you can get some 10 amp large transformer.

Use a hacksaw to cut off the inside wire coil and remove it. This will create an E shaped iron core having a horizontal shape glued to the bottom, the next thing is to determine the radius of the motors you can now make a plywood shaped template, also you will need one for the stator magnets and one for the motor magnets templates of course should be the same size as the same size as the transformer you are using. Ensure you place a piece of thin board and tape them each side of transformer before cutting and shaping it so when you cut the iron laminates you will not pull them loose. The idea is to build a very powerful and large flywheel type engine. I would use a 30" diameter

flywheel and behind it a 25"× 30" diameter deep solid aluminum rotor drum which the rotor isolation transformers would ride on, each roll would consist of 5 transformers to increase horsepower. The firing sequence would be setup in almost the same manner as a DC motors commutator would be, but the difference is you would also have a commutator much like an AC motor added to collect the back Emf, which would have an enormous output of free energy. It is so simple to design. You will be cutting down on performance if you cut into the transformer laminates because they are shorting out which this lowers efficiency, but this engine will still produce free energy by using cut out transformer even when they are shorting out, that is this engine will still go produce free energy when using cut out transformer core. You may also want to customize your own iron core by having them cut to your own special shape and size and then spraying them with lacquer and gluing them together if you have the money you can call up a supply company that carries the special soft iron sheets and have them cut up by a professional in that. But #32 wire is a little difficult to work with and a little hard to solder because it melts easily owing to its lower melting point and breaks very easily. Hence, utmost care should be taken when winding the coils as not to break the wire. If it breaks, then you must clean the coating and of the wire with a lighter and then use a very fine sand paper to clean it off then you should use a low watt soldering iron to apply and attach both pieces back together. After doing this you must

paint the connection with enamel or lacquer paint using a brush. It's also possible to take a high amp DC electric motor and convert it into an over unity free energy motor. You can simply remove the motor and take close pictures of how low the winds connect to the commutator, then you unwind the (amperage hog) wires, once the entire wiring is gone you then spraying the soft iron stator inside and out and with lacquer paint. You must prepare the surface for high voltage or it will spark and burn out and short out the #27 copper coated wire. Let it dry for about 1-2 days then begin winding the iron core stator with the #11 wire. It may be good to mark the connection of where the old wire coil began and stopped although the coil looks like one big connected coil it isn't. Each coil over laps but are not connected, depending on the motors size, there should be about 4-8 separate coils, these must be replaced with #27 wire and put back into place. You must wind it very slowly by hand. Once all the winding is done you can put it back together and try it out. Collect the back Emf and then it should go over unity. This will generate a 12 volt DC motor that once ran at 12 vdc x 5 amps and ran hot, and will now run on 1,000 vdc x 10-30 milliamps which then gets cold. If the back emf is collected properly then you have created a fully working and operational fuel-less engine. You can even decide to replace all the electric motors in your home and watch electric bills go down. Again, your motors will never get hot or over heat! Back Emf is free energy

from a collapsing magnetic field generated from a coil of copper coated wire wrapped around a soft iron core, pulsed by DC voltage.

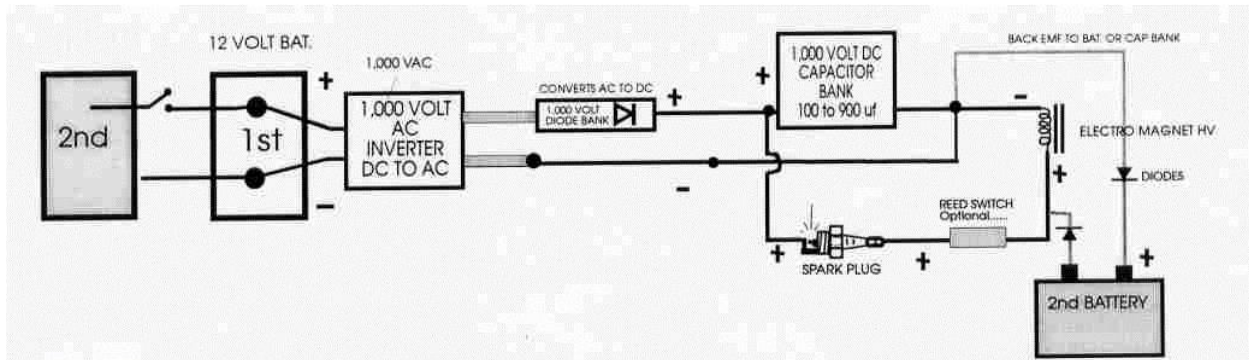

## The Ed Gray Electrical Layout

In the layout above, you will notice that every four high voltage magnet must have a 1000 vdc capacitor bank. But if you want to cut down on cost you can use the same inverter for all 5hv magnets.

The stator housing (the outer case) should preferably be made of aluminum pipe. Aluminum can easily be found at aluminum salvage yards and industrial junk yards in your area. You can decide on the size and horsepower that you want. There are laser cutting companies that will cut metal or aluminum to any size or shape that you want at an affordable price. The rotor plates must be cut by laser and pieced together or hand cut and balanced on a machine shop lathe machine.

Plans

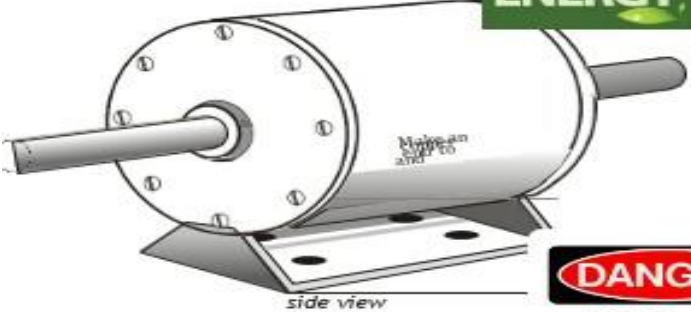

Part#2  
Aluminum Stator Housing

Use the illustrations below as a guide to give to your laser cutting company.

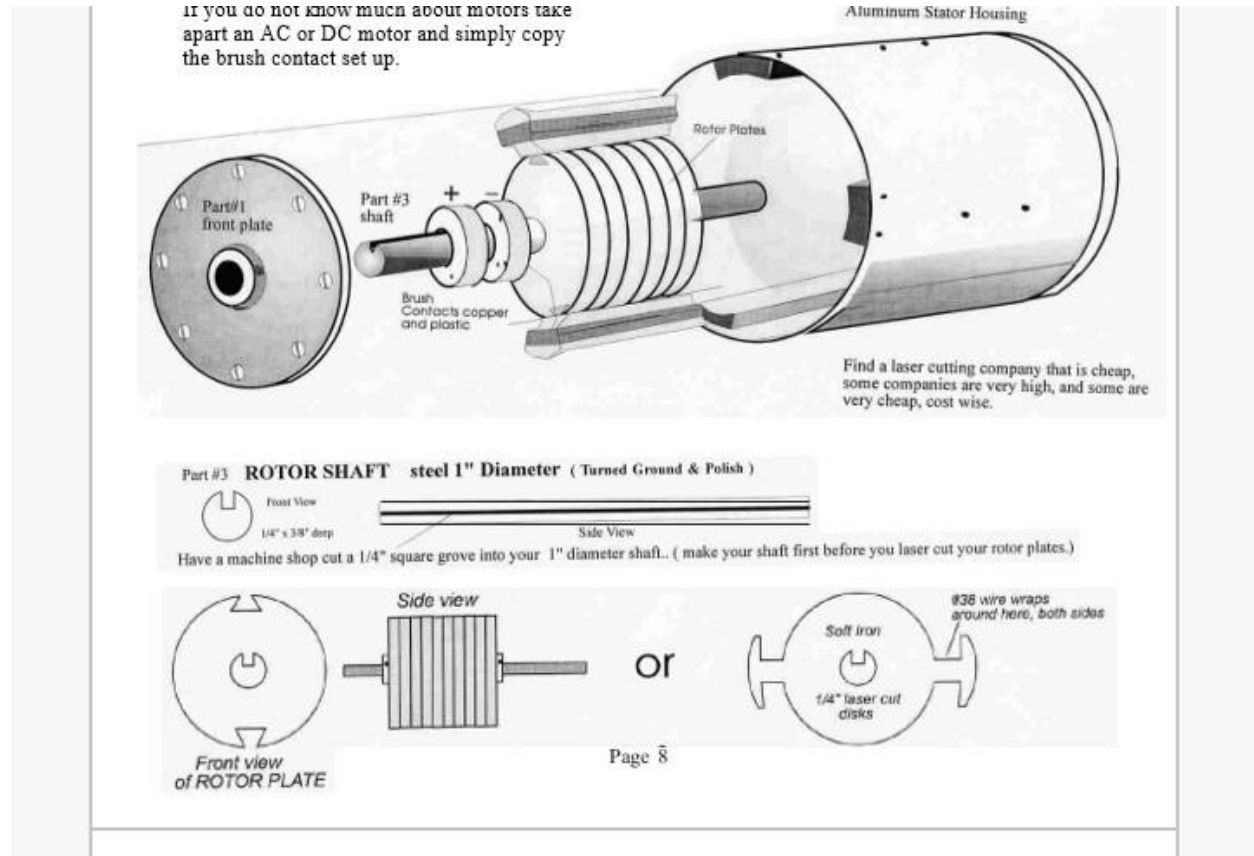

**Part #1** is usually a 1/4 metal or aluminum disk normally attached to the stator housing from the edge, by drilling and tapping out holes on the edge of part #1. But do not worry if you do not know much about motors. All you have to do is take apart an AC or DC motor and simply copy the brush contact set up.

## **Part #4 Rotor Plates**

The rotor plate is a little expensive but your investment will be well worth it if you cut them out of aluminum sheets. It is even cheaper to have these laser cut by using a steel 1/4" plate. Note that it will be heavy if you use 24 steel plates so you can reduce the heavy weight by cutting only 10 steel plates and using 1/2" plywood as spacers. Your brush contacts can be purchased at a hardware store or Grainger's supply, or you can have them laser cut.

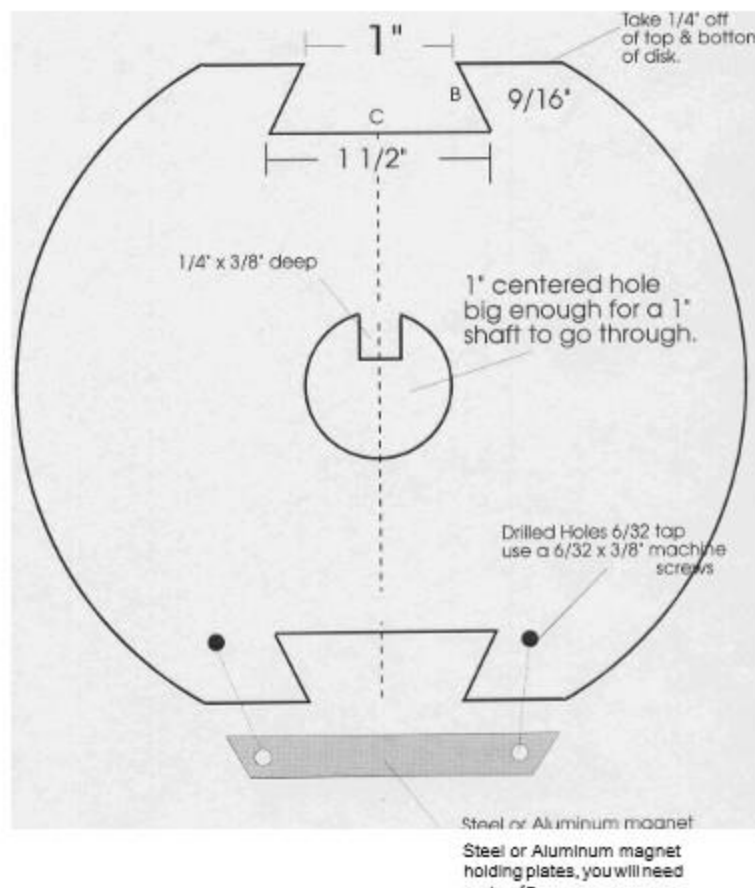

QTY- 24 5" Diameter X 1/4" steel

It is pertinent that the center hole has a 1" motor shaft going through it, it is a turned ground and polished shaft, make a hole about 1 1/32"? Let your machine shop decide that. For Machines, this is a special electric motor, cut b & c does not have to be critical since the magnet's iron core can be cut to fit the size that you desire



## Part #1 Front and Back Plates

The diagram below shows the front and back plates, you will need a Quantity of 2. You will need to have them laser cut and will also need to buy 2 1"pillow bearings for the center shaft to ride on.



The Stator housing should preferably be made of 1/4"aluminum, steel or PVC sewer pipe or wood. But we recommend you use aluminum. For our second prototype we used a 1/4"plexi housing, with aluminum block braces connected to the front and back plates, and there were 4 in all. This took the pressure out to it keep from breaking.

#### **Part # 4 The High Voltage Electromagnets**

These Iron core magnets can be special cut by you or you can decide to have them cut in a machine shop. We recommend you purchase the special soft iron at Industrial Tube & Steel, Cincinnati Ohio , 1-800-332-9567 the Material you want to purchase is called Ductal # 65-4512 and it comes in square bars about 8 feet long. Once you get your soft steel bar you will need to cut it up into 1/2" square wafers, if the steel bar you bought is 4" x 4", then each steel wafer should be 4" x 4" x 1/2". You will need a miter saw or a table saw with a steel cutting disk. But I recommend you let a machine shop cut it up for you. Once you get all your wafers cut up and down one side of each of them until they are semi-smooth, then paint one side of each wafer with flat white spray paint. The diagram below illustrates San example of the soft iron core you will need to shape as you may want to get a rotor plate and make sure it will be a snug fit. Now make a steel or wood template. The template should fit in the rotor plate with a 1/16" play. You will need to

cut an iron core template for the rotor and for the stator, upper and lower. Now use these templates with a pencil and trace out the design onto each steel wafer, (the white painted side) you will now need to cut each wafer with a steel cutting blade using jig saw or a table jig saw. Once you are done, just paint each wafer with a lacquer based spray-paint and leave nothing unpainted, 2 coats will be fine, let dry for 1 to 2 days, then spray each one on one side with clear lacquer. Wait 15 minutes and then while the paint is still tacky, piece each 1/2" wafer together just like a loaf of bread, to make a 4" deep soft iron core. Allow it to dry for 2 to 3 hours then spray the entire assembly of wafers with the lacquer, spray on about 3 to 4 coats, let it dry for 3 to 4 days before you start turning your #32 or #38 copper coated wire around them. You can purchase this wire online or you may have a wire company in your area that sells copper coated wire. These companies sell to motor manufacturers transformer and generator manufacturers and they will also sell to you. Search for them on AOL.com or contact: EIS LouisvilleKY. 502 -636-0384 they will sell you this wire in small spools. You can then wind each magnet by hand or fix up a motor wind of your own. You must wind very slow or you will break the wire and it's hard to solder back together.

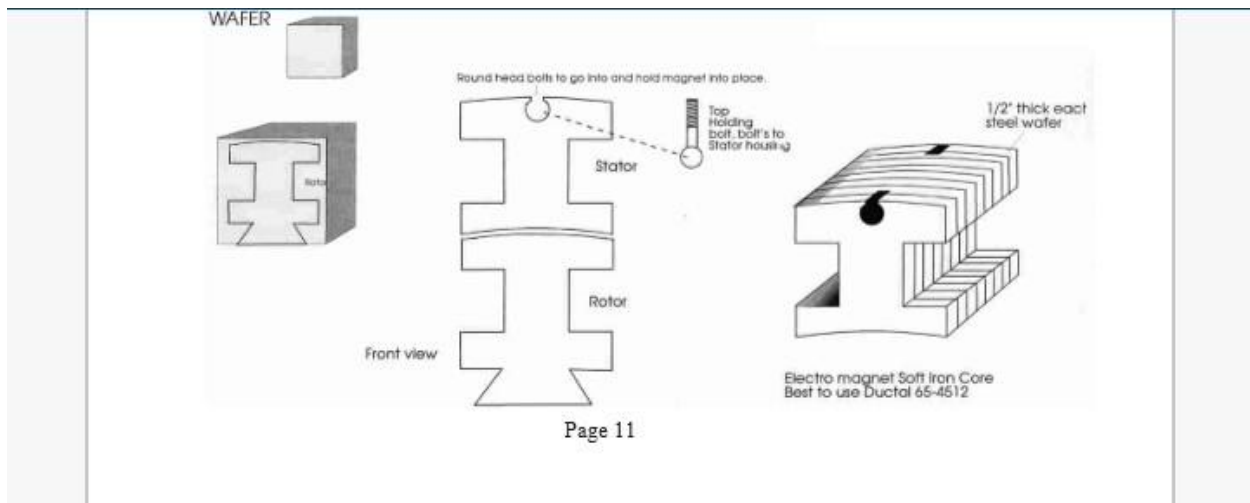

The fuel-less engine operates at about 300 to 1000 vdc rated in milliamps. You can use 115vac \* 500 watt inverter connected to a 12 volt dc battery, and then step transformer or our voltage multiplier plans which uses capacitors and diodes to step up the up the voltage to 300 vdc or up to 1,000 vdc using a high voltage incoming ac current. For the HV Electromagnets: Use # 27 copper coated wire. You may already have a supplier in your area for wire that they sell in spools. You can check your yellow pages phone book for Electric Motor repair shops, they may sell you some or they can tell you where to buy it in your area. But if you still can't find it, you can still purchase it on the internet, e-Bay for instance. Turn your #27 wire around an air core bobbin or a soft iron core. The more turns the better. If you do not know how to build these type of HV Electromagnets, we do sell the plans or you could try your local Library.

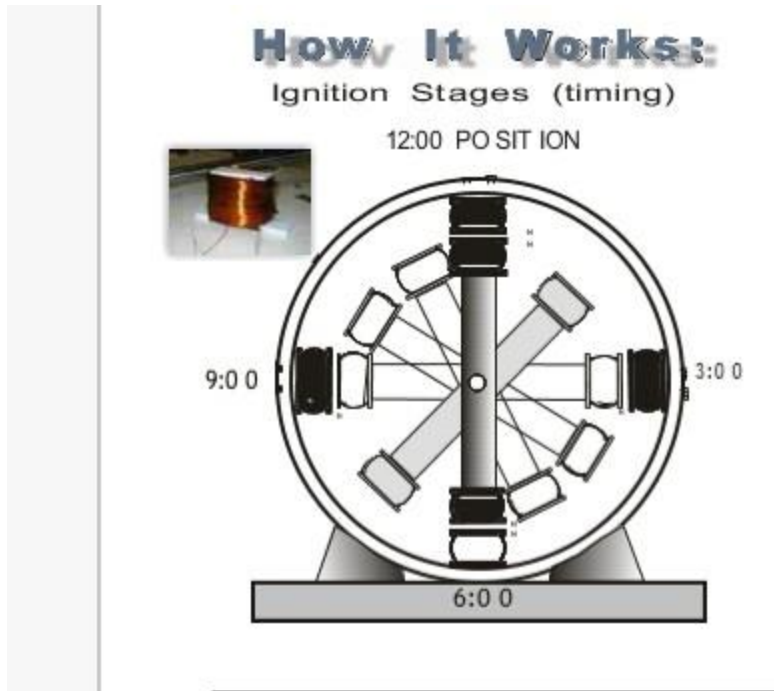

This is essentially a large DC Motor Generator that generates free energy from the coils and caps. A 1000 vdc repulsive explosion takes place at the 12:00 and 6:00 positions, the rotor arm is then forced to the 9:00 and 3:00 positions. The 1,000 volts is switched ON and OFF and it is controlled by our easy to build homemade copper pipe commutator. When timing is adjusted just right, the inner rotor arm and shaft will spin very fast!

The Gray Engine is a Free Energy Perpetual Motion Machine which uses high voltage AC at 60 Hertz. (300 to 1000 volts) in the milliamps. The high voltage is then converted into DC (direct current) through the use of diodes which are rated at twice the voltage of the input voltage. Then the HV dc is directed to a *HV CAPACITOR BANK*.

It would not be possible for the capacitor to operate without the invention of the Capacitor. That is, the capacitor is a major component of the fuel-less engine and motors in general. High voltage in the milliamps can do nothing to a HV electromagnet without the capacitors. What the capacitors do is to quickly store the electrons and generate a great output of *free* amperage. There is something else that we found that happens that we cannot explain; something extra is produced by the high voltage that causes this engine to work. The electrolytic capacitor bank is now fully charged and the spark plug gap is set to fire at 1,000 volts, It then ignites and a complete circuit is made to the magnets which are facing one another north pole to north pole, An explosive amount of magnetic power then takes place and both magnets repel one another, You can use that power to do work, to power a generator to keep up the batteries and to supply power to your entire home..

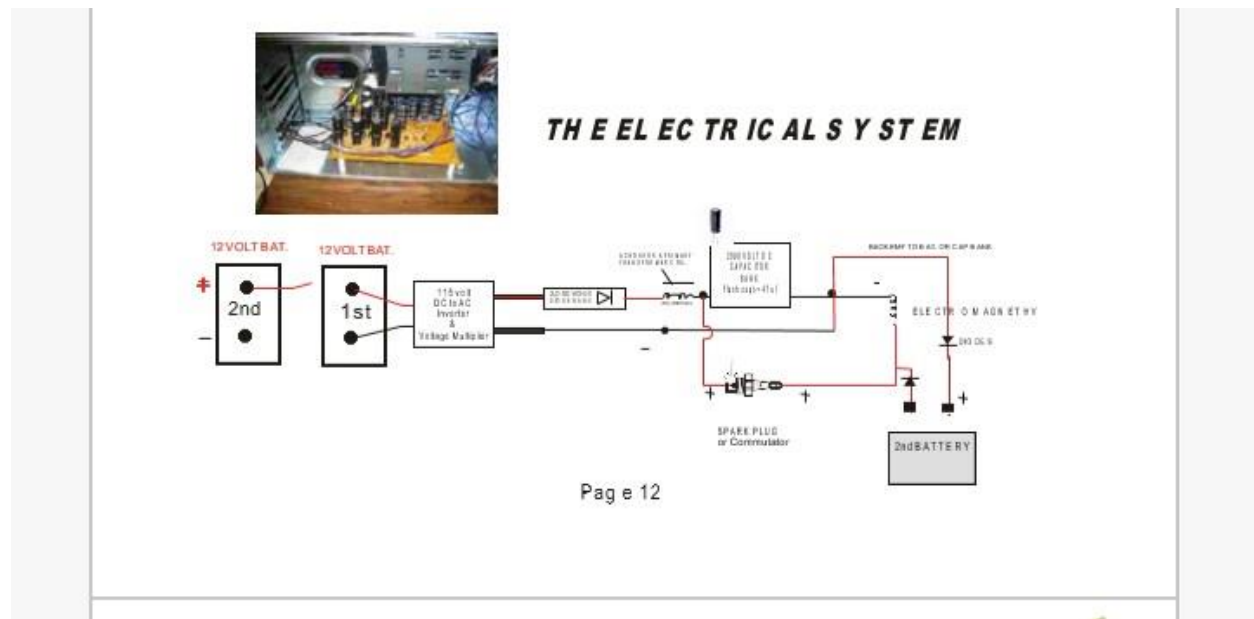

We learn through experience. I remember the first time I tried this I was a bit skeptical and started out using just two electromagnets that I made *myself*. I placed them on the table and I held down the top magnet just in case it did work al because *I didn't want my magnet to get damaged* so with all I could I held *and* pressed down on the magnet with one hand and connected the+ wire lead to the 12 volt battery, then to my surprise it ignited and almost broke my arm, *ouch*, and I still couldn't keep the magnet from flying in the air. That's an experiment that I will never forget.

You cannot get this much power from a low milliamp source using any other electrical DC store bought motor. But our motor will do it!

**NOTE:** The more voltage you use them or epower your engine (Motor) will have, as well as rpms. But anything over 1,600 volts will have to be *well* insulated. Your *soft iron cores of your* electromagnets will have to be dipped in paint and allowed to drip dry for 3 days. Or you can simply buy a 10 LB roll of #30 or so double or triple coated copper wire. You can also buy the square type and you will get more power but be sure to wrap wire as tight as you can, side by side as close as you can.

The center Rotor rotates within the Stator Housing. After you have turned it on and each capacitor bank powers up to its firing spark potential then all you need to do is start it by spinning the shaft by hand

or starter motor. Assuming you start it in the 12:00 position it then ignites pushing it to the 9:00 position and the brush timing contacts hit and ignites all 4 magnets again pushing it to the 6:00 position and so on. Of course this all happens so fast and with so much power that you can't see it. To give you an idea about what is happening flip a bicycle on its back and spin the front tire as fast as you can repeatedly with as much power as you can. You see a little of what happens inside this engine but with 100 times more power made by the repulsion of the magnets. The weight of the magnets and rotor and the inertia.

**Note:** the rotor can be made with just one magnet and a counter balance, it will work just fine but with less horse power. The best motor to build is the 1 hp type, which we have included in these plans. For more horse power simply scale it up. Using air core electromagnets are by far the best way to go. The finer the wire you use and the more turns of wire, the more free energy output you will have, but motor input voltage must go up. Using the fine wire will cause the motor to run with very little amperage at all, and then the Free Energy back EMF can then be used to replenish the 12 volt battery or batteries. The finer the wire the harder it is to turn. Hair thin wire breaks very easy.



## **PARTS LIST**

In order to construct your own gray generator you're going to need the following items

1 Quantity of 3500 to 5000 volt DC to AC inverter 30 Hz to 60 Hz

4 Quantity of Spark plugs type champion copper with 855 DJ7Y or anything close

2 Quantity of 12 volt car batteries or 4 quantity of 6 volt batteries

6 Quantity of 5000 volt DC Electromagnets

8 Quantity of 2000 volt diode or diode bank

1 Quantity of transformer. Please use primary only

You will also need electrolytic capacitors rated 400 volt \* 470 uf. The capacitors should preferably be connected in series using a soldering iron. The importance of using electrolytic capacitors lies in the fact that they have the advantage of charging very quickly, they will not store much amperage since the finer the wire you use and the more turns of wire you use the less amperage you will need to run your motor. Furthermore, the higher the uf value of the capacitors the more amperes (current) it will store. Although it will take longer to start up the engine but once fully charged your capacitor will discharge very slowly because your motor is designed to run at very low milliamps of power. It is recommended that you use MDO board or some other strong thin wood

for the coil bobbin, on our 1 hp motor we used 1/8 pvc sheeting, made a square center and then glued the top and bottom into it using PVC pipe glue. Furthermore, this motor can also be built using plastic PVC air core magnets or soft iron core magnets.

2 Quantity of ball bearing which is required for the center shaft to ride on. A 3/16 inches bore size or whatever diameter is suitable to your need is recommended although it is easier to work with a 5/8" since it is a standard pulley size

1 Quantity of heat treated round rod metal shaft 8 \* 3/16"

4 Quantity of large PC boards, thin Rosin Core Solder 1-roll, 100 WA soldering iron, 1 quantity. This will be needed for soldering capacitors and diode banks

1 quantity of 15" diameter \* 12" deep \* no less than 1/8" thick steel or wood drum. We recommend you use a wood drum from a Ludwig drum set which is also the one we used for our prototype. This also has the added advantage since it has the ability to be scaled up and down

14-nuts and bolts to hold down magnets unto drum, about 1/4" \* 2"

One 12 volts DC 60 to 100 amperes generator for keeping up an inverter battery system or you can use a 10 000watt 120 volt AC generator

1 8" \* 5/8" aluminum pulley grangers which can be obtained at a hardware store. If you use a 5/8" pulley with the 3/16" shaft you will need bronze bushings or steel sleeves to fill the gap.

One 12 volt ON/OFF switch and an off key switch

Four spark plug wires that is needed to attach to spark plug and to capacitor bank. The type used in lawn mower can also be used and they have been shown to work efficiently and can be obtained at hardware stores

One 500 or 1000 Watt inverter which converts DC battery to AC 115 volt 60 Hz to a diode and cap multiplier which in turn changes the 2000 volt capacitor or cap bank

**NOTE:** If you are using soft iron core the high voltage input has more of a chance to arc and burn out your coil.



## **TIMING OF FUELLESS ENGINE**

If you are new to the field of DC motors and you want to get an idea of how a DC brush motor works. All you have to do is to take apart any size DC motor and check it out. Study it carefully

Timing the Fuel less Engine: 1,000 vdc is applied to the brush assembly. The brush assembly acts as an ON and OFF switch for each set of magnets. The brush assembly can be made in many ways. The timing takes place in two places, the spark plug caps or the commutator brush collar assembly. You will only need one 1000 vdc charging and firing system that is rated at 1 to 3 amps, the more amps the better, but the more danger to you during assembly. You can experiment around with a low milliamp cap bank and power supply, 10 amperes is safe to use.

You will need two spark plugs, two sets of capacitor banks or capacitors and one or two diode banks. One diode bank is for the Positive side and the second one is for the negative side. When the rotor arm magnets #5 & 6 are in the 12:00 position contact should be made to fire #1, #5, #6 & #3 magnets all at the same time. Wire these magnets so they are North Pole to North Pole, or north to south which will cause motor to then be an attraction motor. Many think that an attraction motor is better? But if you are using this as a repelling motor then time the firing when the arm #5 is just 1/16" past the center of #1 stator magnet. This will insure that

the rotor arm will be pushed and rotated to the left and rotate counter clock wise. If timing as an attraction motor, you will want #5 to fire at about 3 to 4 inches before it gets to #1 magnet. This motor can be times to run clock wise as well. Collect all back emf per coil using a diode and capacitor per magnet, on the negative side outputs. It is strongly recommended that you build our 1 hp motor to get more understanding of how to build this motor.

If you choose to use a spark plug, you can gap the spark plug to fire a little early which will cause your power up time to be less, but you will have less shaft torque (HP). In other words you will have more RPMs but with somewhat less Horse Power, Now this is not real bad because it depends on what kind of generator you're going to use.

Please NOTE: the engine must be timed just right so the rotor magnets do not repulse each other too soon. Repulsion must take place at center or 1/16" past left or right. (This prototype uses a 115 volt AC generator, Please note: This engine design rotates to the left only counter clockwise.) You can design it to rotate both ways. Also Note: A & B Magnets connect to the same + & - Brush Rotor Assembly.

## HOW TO BUILD THE COMMUTATOR

### A BRIEF DESCRIPTION OF DC MOTORS/GENERATORS

#### DC Motor/Generator (Introduction)

Electric motors are the interface of electronic boards to almost every mechatronic and mechanical product including robots, drones, home appliances, etc. A DC motor is an electrical machine devised to convert electrical energy into mechanical energy. The main principle behind working a DC motor is the electromagnetic law according to which a current carrying conductor placed in magnetic field experiences a force, and the direction of the force is given by Fleming's left-hand rule. In order to understand the basic principles, we need to understand the basic constructional features of a DC motor.

Every DC motor has 6 parts. Axle, Rotor, Commutator, Field magnets, and Brushes.

The basic component of a DC motor is a current carrying armature which is connected to the supply end through the commutator segment and brushes. The armature is

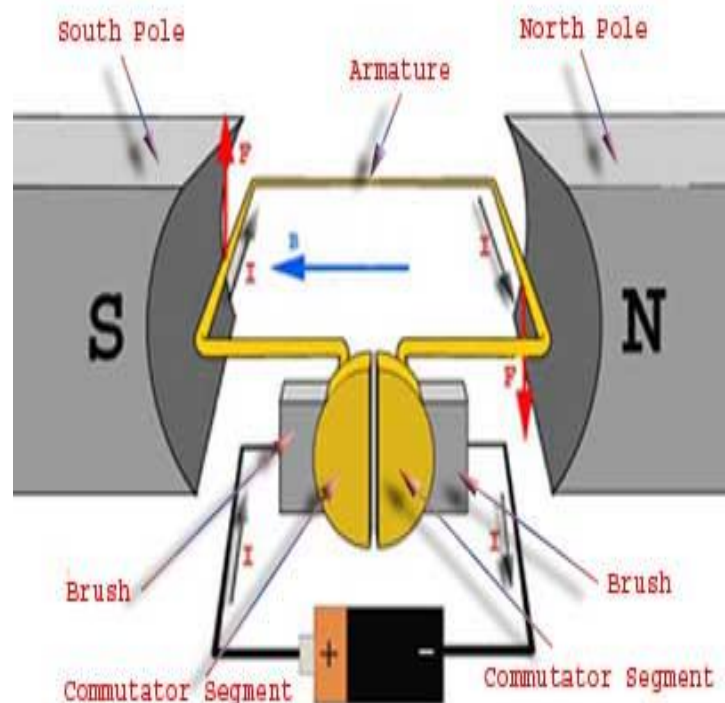

placed between two permanent magnets which produce a magnetic field. The applied direct current converts the electrical energy into the mechanical energy because of the interaction of two magnetic fields. One field is produced by the permanent magnet and the other is produced by the electric current flowing through the armature winding. Because of the interaction of these two fields, the armature experiences a force which tends to rotate the rotor. This is how a DC motor Works.

In order to build a commutator it is important to have a good understanding of what a commutator really is. In very simple words commutator converts ac into dc. Simple right? A coil rotates a magnetic field which creates AC and commutator converts it to DC. In electrical motors and generators, a commutator is a segmented metallic ring which carries electric current to the rotating component. Stationary "brushes" (usually carbon blocks) rest against the ring and supply electric current. As the commutator rotates, it switches the current from one coil to another in the rotor. In a motor, this maintains the proper relationship between stator and rotor magnetic fields. In a generator, it converts the AC current from the rotor into DC



We are going to describe the homemade Commutator designed by Rick and Dave, This DC Commutator is used to turn off the incoming DC voltage to the HV Voltage or Low Voltage Magnetic Coil. We are going to create a junction bar that rotates and as it rotates it will slide onto the 2 carbon DC motor brushes and cause a complete connection causing DC current to flow into the Electromagnetic coil. We are going to give you 2 options in making a DC motor commutator.

**STEP ONE:** Cut a piece of  $\frac{3}{4}$ ” Diameter” x 1  $\frac{3}{8}$ ” length copper pipe that you can buy at any hardware store. Use a pipe cutter to cut a piece 1  $\frac{3}{8}$ ” long.

**STEP TWO:** Next using rough sand paper, sand the inside of the copper pipe really good. And then clean with lacquer thinner. Surface must be free from dirt.

**STEP THREE:** Pick Using a Q-Tip, Grease a piece of card board a little larger than the copper pipe diameter, this is so the epoxy will not stick to the Card board surface and can be removed when dry. You now need to fill the copper pipe with Epoxy, so slowly squeeze out enough J-B Epoxy to fill the inside of the copper pipe, follow all directions on the J-B Instructions, Mix the 2 parts very well and start placing the epoxy inside of the copper pipe. Let dry 24 hrs. I prefer to wait 40 hrs. But the instruction do not tell you that. We use J-B Epoxy because it is the best on the market and can stand up to 600 degrees.

**STEP FOUR:** Now you must find the exact center of the pipe and score it with a sharp punch. You will be scoring or punching a small hole into the top of the epoxy. Now you are going to need a drill press. Place the copper pipe up as you see in figure #3, Make sure bottom surface is very flat, if it is not the hole will be crooked and the commutator will ride with the shaft crooked and cause an off balance at high speeds. Start off with the smallest drill bit you have and work your way up until you have a hole the same size as your shaft rods outer diameter.

**STEP FIVE:** Now using a fine point marker, mark your cut marks on the outside of the copper pipe piece. As shown in figure #4. Use a fine tooth hacksaw to cut. Cut a long center cut all the way around the copper pipe leaving a 3/4" space. Cut all the way through the copper and just up to the hardened epoxy fill. Do not cut too deep into the epoxy fill.

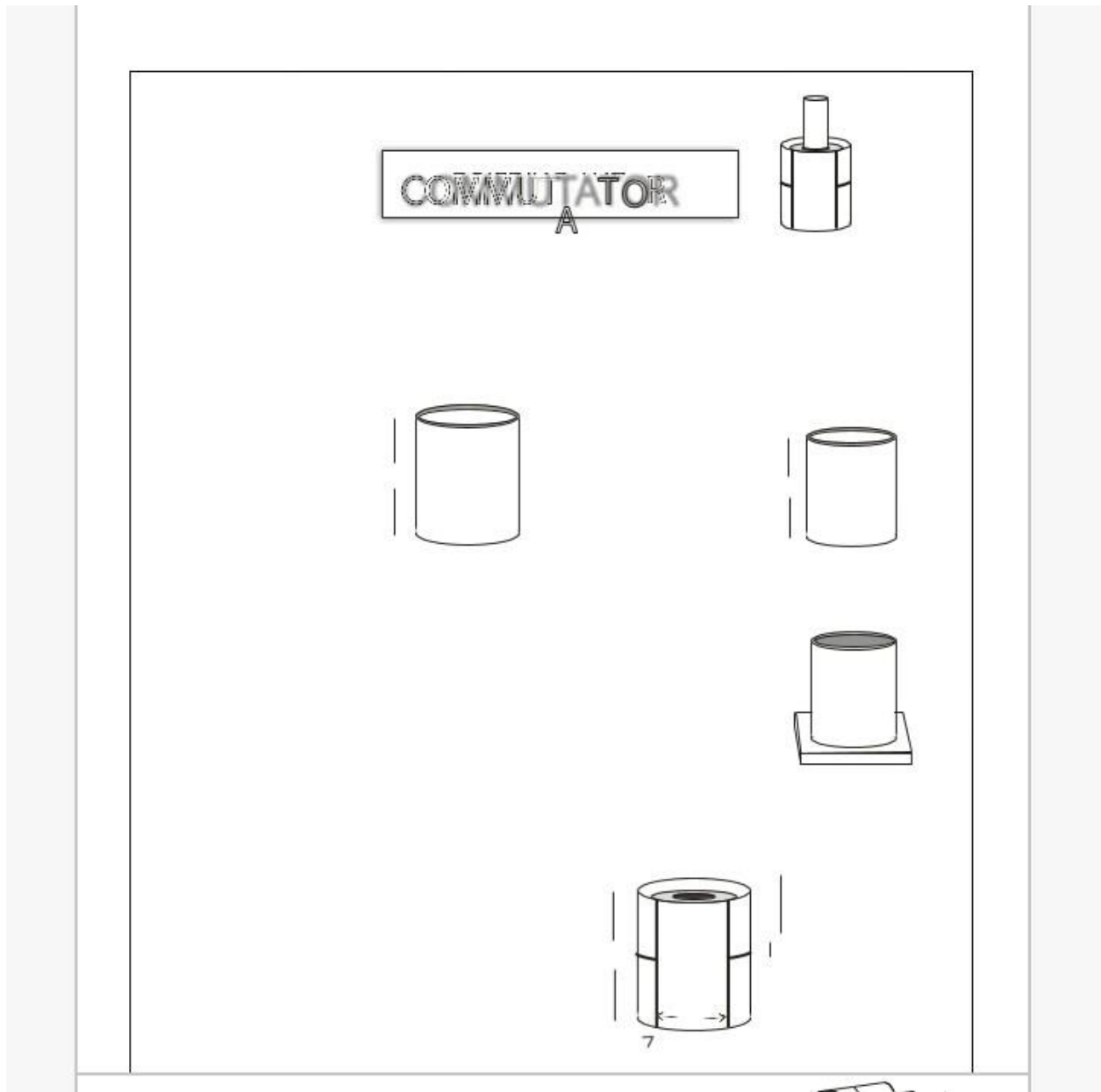

It is important to remember that this is a research device, Capacitor and diode ratings depend on the voltage input vs. what size coil wire used and # of winds. If you use a coil that is wound several thousands of times with number 38 or 36 copper coated wire, you are going to need to use voltages from 1000 to 3,500 vdc input. The back emf will be great.

# 38 wire is hair thin and hard to wind but it is the best to use for a PVC air core type magnet.

---



The Ultimate Free Energy Device

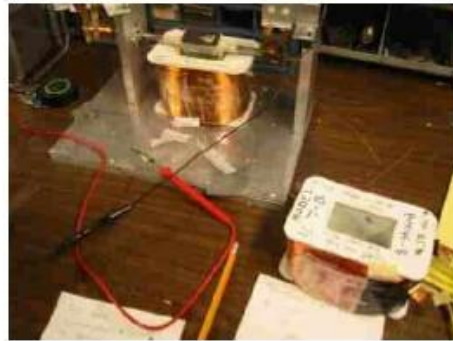

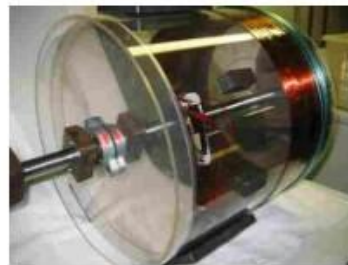
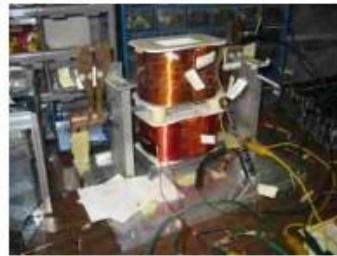
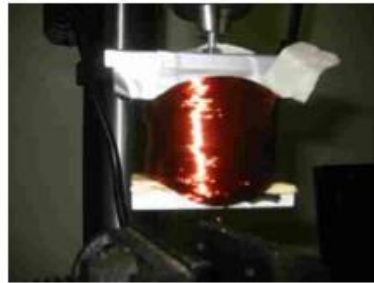

Using # 36 or 32 copper coated wire is much easier to work with. Make several coils out of old transformer iron cores. You will need to do a little cutting. This will be a great learning experience for you when you go to build a larger unit. Make one coil with #18 copper coated wire which should come out to be about 90 to 100 turns, you will notice that free energy can be collected but the coil and commutators run hot, heat

loss = energy loss. # 18 wire will take voltages from 12 to 24 vdc. #38 wire will take voltages from 200 to 3,500 vdc. And will run very cool and use very little amperage from your DC power supply, use a 12 vdc battery with a small 100 watt dc to ac inverter.

You will need Copper coated wire to wrap around your soft Iron Cores, You will want to build up to 4 different. Electromagnetic Coils with different size wire for study and research purposes. Teachers show your students the different effects and outputs that this Motor Generator will make by using more turns of wire vs. less turns and the wire size. Make your Magnets interchangeable. Collect the Back Emf to and use the Vortex Effect to show your students how to get Free Energy out of there motors

Use #16 gauge or #18 Gauge copper coated wire to make a Spiral. This demonstrates an amperage hog motor, Place this Spiral under the motor shaft. Run test and note what happens.

To make a Spiral coil, use two pieces of flat plexi glass or MDO board, drill a center hole in both, sandwich the 2 pieces together leaving a metal or cardboard spacer in between the 2 boards, the spacer washer must be the same size thickness as the wire. Now place a bolt in the center hole and attach a nut. Now drill a small hole nest to center hole so you can run the first part of your wire through, tape it down and begin turning wire

DC Motor / Generator

**PART "F"**  
**BRUSH HOLDER**  
ASSEMBLY

Cut two 1 5/16" x 1/2" x 1/2" x 1/16" Square steel.

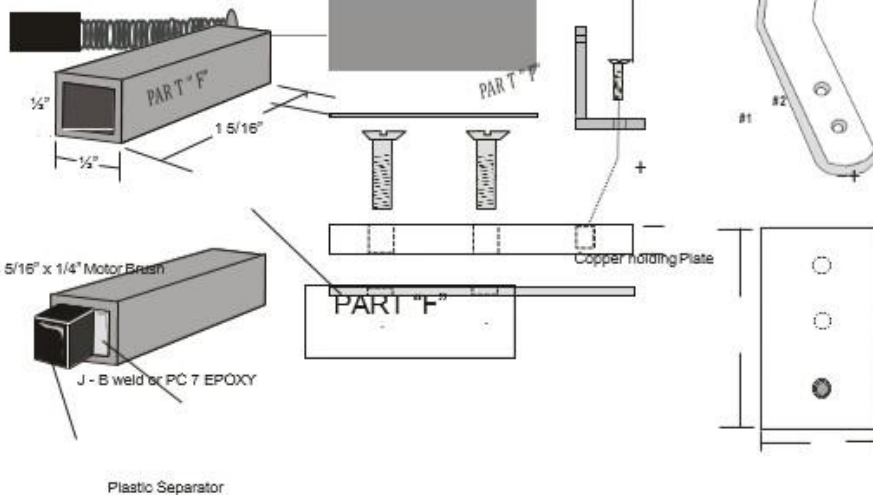

Fill with PC 7 Epoxy or J - B weld about 1/4" deep.

Brush: grease brush and place inside of square steel part # "F", Lets it and dry for 24 hrs, then remove brush and clean it ou.

As an alternative to using brushes, you could replace with heat treated copper, which has some spring to it. Place the copper on part "M" and bend the copper upward.

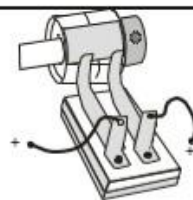

## **CERAMIC MAGNETS (INTRODUCTION)**

Ceramic magnets (also known as ferrite magnets) were developed in the 1960's as a low cost alternative to metallic magnets. Ideally, they are composed of iron oxide and strontium carbonate. While their hard, brittle quality and low energy exclude them from some applications, ceramic magnets have won wide acceptance due to their corrosion and demagnetization resistance, and low price per pound. Ferrite represents more than 75 percent of world magnet consumption (by weight). It is the first choice for most types of DC motors, magnetic separators, magnetic resonance imaging and automotive sensors. Ceramic magnets are manufactured using powder technology techniques. The primary raw material – ferrite – is made by using iron oxide and strontium carbonate. These materials are mixed together and then elevated in temperature to 1800-2000 degrees F. At this temperature they undergo a chemical conversion and the resulting material is ferrite.

The ferrite material is then reduced to a very small particle size by wet milling. The milled powder is then either dried (for dry pressed material) or injected into a die (in wet slurry form) in a large hydraulic press. The die is non-magnetic steel with carbide liners. The die cavities are the shape of the part to be pressed.



The wet powder (slurry) is then compacted in the presence of a magnetic field. The water allows the flat ferrite particle to more easily align itself in the magnetic field. Most of the water is removed during the compaction process. The remaining water is evaporated during the initial stages of the sintering process. The sintering takes place at 2000 degrees F. approximately. After sintering the material is fully dense and ready for finish grinding to customer specifications. As the material is very hard and brittle, all of the grinding of ceramic magnets is done using diamond wheels.

For this motor you will need 2 powerful ceramic permanent magnets, you can buy these from Radio Shack or search the internet for magnet suppliers. If you want to increase your horsepower then you must add more magnets to your shaft, on this motor you can get 2 pair. Make sure to redesign your magnetic coil structure to be longer. You can also design a large HP motor with Radio shack magnets by buying a hex shaped metal rod, and gluing 24 magnets to it. This will also ensure that your permanent magnets will last a very long time. For the more advanced: Use an aluminum or steel Hex Bar, have a machine shop round off the ends to fit your end bearings. Epoxy each magnet onto the hex bar. Example length, 18 3/8" long. Use 1" hex flats. This will make for a very powerful free energy motor.

For the purpose of this motor you will need about 2 powerful ceramic permanent magnets which can be obtained from Radio Shack or online

stores like e-Bay. You can also scale-up your horsepower by adding more magnets to your shaft, on this motor you can get 2 pair. Ensure you redesign your magnetic coil structure to be longer. You can also design a large HP motor with Radio shack magnets by buying a hex-shaped metal rodgluing 24 magnets to it. This also has the advantage of increasing the lifetime of your permanent magnet.

But if you have experience with DC Motors you can use an aluminum or steel Hex Bar, have a machine shop round up the ends to fit your end bearings. Epoxy each magnet onto the hex bar. Example length, 18 3/8" long. Use 1" hex flats. The end result will be a very powerful free energy motor.

Insure that your permanent magnets will last a very li

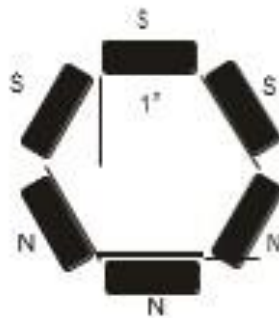

Page



Page 26

## A letter sent in by a customer

To the technician  
at Creative Science,

After studying your file, "The Fuelless Engine" I Downloaded, from the internet, a copy of U. S. Patent # 3,890,548 for further study. These devices, as stated, appear to work by the conservation of energy, and the electronic coupling of energy, while collecting the electron moving forces of decaying magnetic fields after physical work as been accomplished.

On page 8 of your file you state that you would appreciate any new ideas and findings. It seems easier to understand how this engine works with the concept of inductance in mind. Your file arranged like this might be easier for the layman to understand.

I noticed in the descriptions of the illustrations in Ed V Gray's patent, something that wasn't apparent at firsts. Number 32 in figure 1; is a second complete charging system! That leaves me to believe that power might flow through the system like this.

### POWER ROUTE

Figure 1  
Sub Figure

10	Battery one		Battery two
16,20	Charging system one		Charging system two
21,21a	Diodes(bottom of sine wave 21a)	22,22a	Diodes(top of S. wave 22a)
23	Choke coil	24	Choke coil # two
26	Capacitor bank	25	Capacitor bank
28	Inductor(Magnets)	27	Inductor(magnets)
	E.M.F. to battery two		E.M.F. to battery one

In Ed V Gray's diagrams: see figure one; The sinewave(s) are split differently, see sub-figures 19a, 21a, 22a. This might be what he considers, "splitting the positive." He uses diodes (#'s 21 & 22) to rectify the positive's of two opposite, unidirectional sinewaves.



In my opinion the negative waves of these currents are transformed/harnessed as flux. The Inductors(#'s 23 & 24), along with the inductance of the magnets could influence the way the flux reacts in nature/reality. Splitting the positive(s) and exciting the currents into flux seems to be where the efficiency is achieved.

Your simplified model is sound in theory. However, the illustrations don't contain any reference to the DELAY COILS/INDUCTORS of the charging systems, nor to the important role they play in the system. As I understand it, when current is increased in an inductor, the inductor generates a counter E.M.F. which opposes current build up. As current decreases, the inductor sets up a counter E.M.F. to try to keep the current going the same way. This is accomplished by the magnetic field expanding and contracting in the core of the inductor. This concept tends to cause the power to be "OUT OF PHASE". Ed Gray states in his patent, "which is believed to produce a static floating flux field." The word static, may be a reference to the way power flows at a molecular level. In the delay coils the inductance also seems to be applied as a flux(magnetic field? or?) and as a phase variant in how it interacts with other inductors (stator and rotor electromagnets). The floating part of it?? Hence, "static floating flux field". In the magnets power and current being out of phase seems to be how Ed V Gray has been able to recover so much energy. This may also help illustrate, "that something extra that is produced by high voltage that can't really be explained.

